

Asynchronous Communication Interface Adapter

Features

- On-chip baud rate generator: 15 programmable baud rates derived from a standard 1.8432 MHz external crystal (50 to 19,200 baud).
- Programmable interrupt and status register to simplify software design.
- Single +5 volt power supply.
- Serial echo mode.
- False start bit detection.
- 8-bit bi-directional data bus for direct communication with the microprocessor.
- External 16x clock input for non-standard baud rates (up to 125 Kbaud).
- Programmable: word lengths; number of stop bits; and parity bit generation and detection.
- Data set and modem control signals provided.
- Parity: (odd, even, none, mark, space).
- Full-duplex or half-duplex operation.
- 5, 6, 7, 8 and 9 bit transmission.

Description

The SY6551 is an Asynchronous Communication Adapter (ACIA) intended to provide for interfacing the 6500/6800 microprocessor families to serial communication

data sets and modems. A unique feature is the inclusion of an on-chip programmable baud rate generator, with a crystal being the only external component required.

Pin Configuration

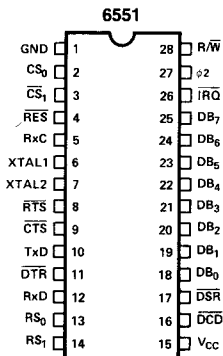

Block Diagram

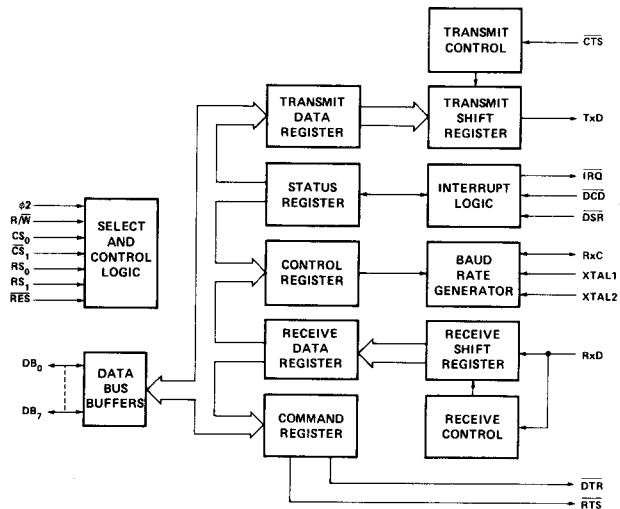

MICRO-PROCESSORS

Absolute Maximum Ratings*

Rating	Symbol	Allowable Range
Supply Voltage	V_{CC}	-0.3V to +7.0V
Input/Output Voltage	V_{IN}	-0.3V to +7.0V
Operating Temperature	T_{OP}	0°C to 70°C
Storage Temperature	T_{STG}	-55°C to 150°C

All inputs contain protection circuitry to prevent damage to high static charges. Care should be exercised to prevent unnecessary application of voltages in excess of the allowable limits.

Comment*

Stresses above those listed under "Absolute Maximum Ratings" may cause permanent damage to the device. This is a stress rating only and functional operation of the device at these or any other conditions above those indicated in the operational sections of this specification is not implied.

D.C. Characteristics ($V_{CC} = 5.0V \pm 5\%$, $T_A = 0-70^\circ C$, unless otherwise noted)

Characteristic	Symbol	Min	Typ	Max	Unit
Input High Voltage	V_{IH}	2.0	—	V_{CC}	V
Input Low Voltage	V_{IL}	-0.3	—	0.8	V
Input Leakage Current: $V_{IN} = 0$ to 5V ($\phi 2$, R/W , RES , CS_0 , \overline{CS}_1 , RS_0 , RS_1 , \overline{CTS} , RxD , \overline{DCD} , \overline{DSR})	I_{IN}	—	± 1.0	± 2.5	μA
Input Leakage Current for High Impedance State (Three State)	I_{TSI}	—	± 2.0	± 10.0	μA
Output High Voltage: $I_{LOAD} = -100\mu A$ ($DB_0 - DB_7$, TxD , RxC , \overline{RTS} , \overline{DTR})	V_{OH}	2.4	—	—	V
Output Low Voltage: $I_{LOAD} = 1.6mA$ ($DB_0 - DB_7$, TxD , RxC , \overline{RTS} , \overline{DTR} , \overline{IRQ})	V_{OL}	—	—	0.4	V
Output High Current (Sourcing): $V_{OH} = 2.4V$ ($DB_0 - DB_7$, TxD , RxC , \overline{RTS} , \overline{DTR})	I_{OH}	-100	—	—	μA
Output Low Current (Sinking): $V_{OL} = 0.4V$ ($DB_0 - DB_7$, TxD , RxC , \overline{RTS} , \overline{DTR} , \overline{IRQ})	I_{OL}	1.6	—	—	mA
Output Leakage Current (Off State): $V_{OUT} = 5V$ (\overline{IRQ})	I_{OFF}	—	1.0	10.0	μA
Clock Capacitance ($\phi 2$)	C_{CLK}	—	—	20	pF
Input Capacitance (Except XTAL1 and XTAL2)	C_{IN}	—	—	10	pF
Output Capacitance	C_{OUT}	—	—	10	pF
Power Dissipation (See Graph) ($T_A = 0^\circ C$) $V_{CC} = 5.25V$	P_D	—	170	300	mW

Power Dissipation vs. Temperature

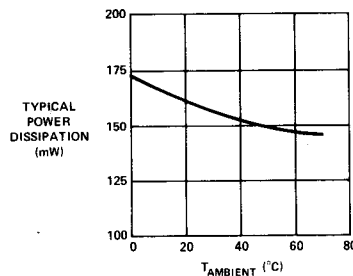

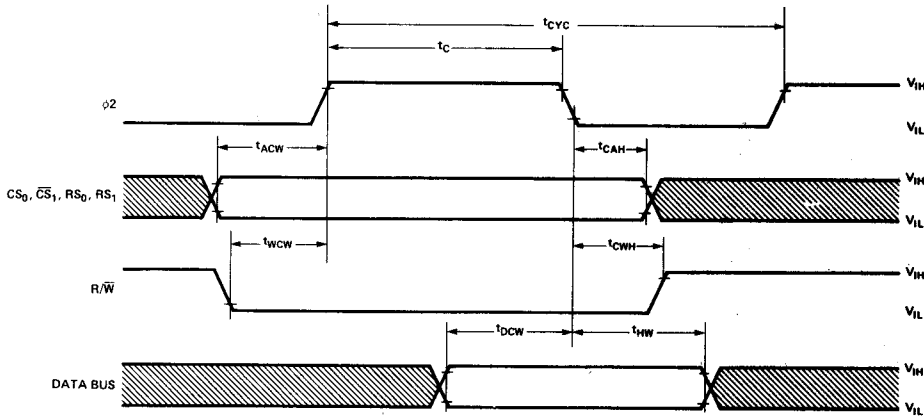

Figure 2. Write Timing Characteristics

Write Cycle ($V_{CC} = 5.0V \pm 5\%$, $T_A = 0$ to $70^\circ C$, unless otherwise noted)

Characteristic	Symbol	SY6551		SY6551A		Unit
		Min	Max	Min	Max	
Cycle Time	t_{CYC}	1.0	—	0.5	—	μs
$\phi 2$ Pulse Width	t_c	400	—	200	—	ns
Address Set-Up Time	t_{ACW}	120	—	70	—	ns
Address Hold Time	t_{CAH}	0	—	0	—	ns
R/ \overline{W} Set-Up Time	t_{WCW}	120	—	70	—	ns
R/ \overline{W} Hold Time	t_{CWH}	0	—	0	—	ns
Data Bus Set-Up Time	t_{DCW}	150	—	60	—	ns
Data Bus Hold Time	t_{HW}	20	—	20	—	ns

(t_r and $t_f = 10$ to 30 ns)

Crystal Specification

1. Temperature stability $\pm 0.01\%$ (0° to $70^\circ C$)
2. Characteristics at $25^\circ C \pm 2^\circ C$
 - a. Frequency (MHz) 1.8432
 - b. Frequency tolerance ($\pm\%$) 0.02
 - c. Resonance mode Series
 - d. Equivalent resistance (ohm) 400 max.
 - e. Drive level mW 2
 - f. Shunt capacitance pF 7 max.
 - g. Oscillation mode Fundamental

No other external components should be in the crystal circuit

Clock Generation

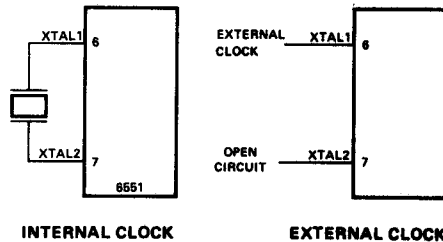

MICRO PROCESSORS

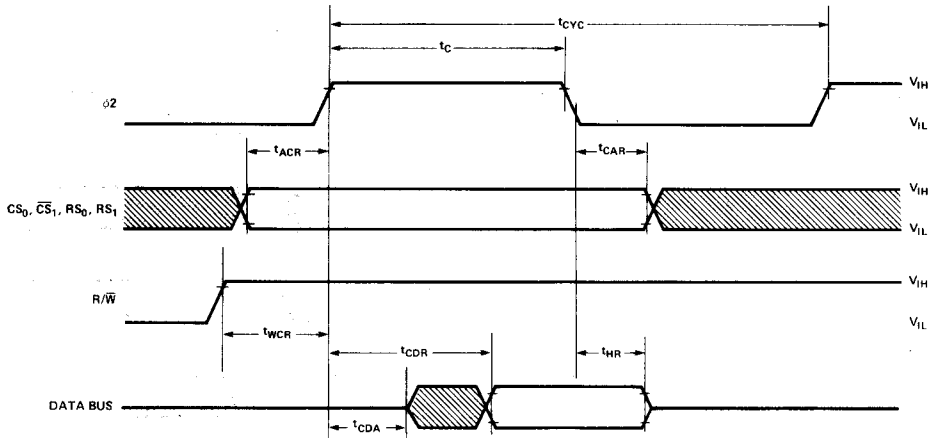
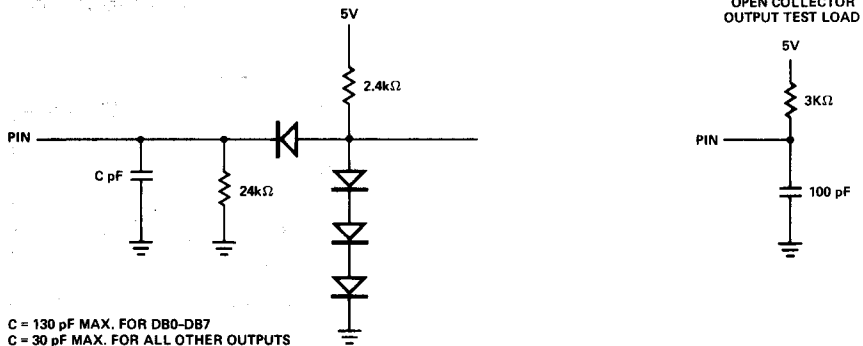

Figure 3. Read Timing Characteristics

Read Cycle ($V_{CC} = 5.0V \pm 5\%$, $T_A = 0$ to $70^\circ C$, unless otherwise noted)

Characteristic	Symbol	SY6551		SY6551A		Unit
		Min	Max	Min	Max	
Cycle Time	t_{CYC}	1.0	—	0.5	—	μs
Pulse Width ($\phi 2$)	t_C	400	—	200	—	ns
Address Set-Up Time	t_{ACR}	120	—	70	—	ns
Address Hold Time	t_{CAR}	0	—	0	—	ns
R/\bar{W} Set-Up Time	t_{WCR}	120	—	70	—	ns
Read Access Time (Valid Data)	t_{CDR}	—	200	—	150	ns
Read Data Hold Time	t_{HR}	20	—	20	—	ns
Bus Active Time (Invalid Data)	t_{CDA}	40	—	40	—	ns

Test Load



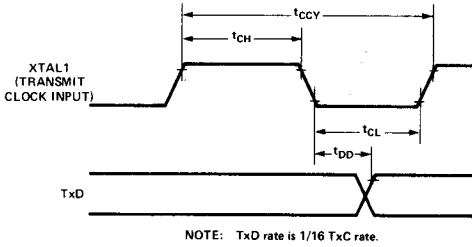

Figure 4a. Transmit Timing with External Clock

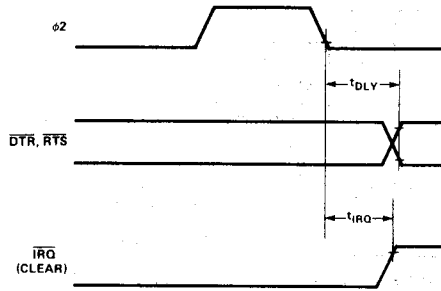

Figure 4b. Interrupt and Output Timing

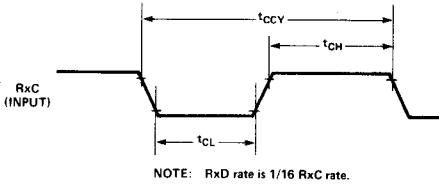

Figure 4c. Receive External Clock Timing

Transmit/Receive Characteristics

Characteristic	Symbol	SY6551		SY6551A		Unit
		Min	Max	Min	Max	
Transmit/Receive Clock Rate	t _{CCY}	400*	—	400*	—	ns
Transmit/Receive Clock High Time	t _{CH}	175	—	175	—	ns
Transmit/Receive Clock Low Time	t _{CL}	175	—	175	—	ns
XTAL1 to Tx D Propagation Delay	t _{DD}	—	500	—	500	ns
Propagation Delay (RTS, DTR)	t _{DLY}	—	500	—	500	ns
IRQ Propagation Delay (Clear)	t _{IRQ}	—	500	—	500	ns

(t_r, t_f = 10 to 30 ns input clocks only)

*The baud rate with external clocking is:
$$\text{Baud Rate} = \frac{1}{16 \times T_{CCY}}$$

Interface Signal Description

RES (Reset)

During system initialization a low on the RES input will cause internal registers to be cleared.

phi2 (Input Clock)

The input clock is the system phi2 clock and is used to trigger all data transfers between the system microprocessor and the SY6551.

R/W (Read/Write)

The R/W is generated by the microprocessor and is used to control the direction of data transfers. A high on the R/W pin allows the processor to read the data supplied by the SY6551. A low on the R/W pin allows a write to the SY6551.

IRQ (Interrupt Request)

The IRQ pin is an interrupt signal from the interrupt control logic. It is an open drain output, permitting

several devices to be connected to the common IRQ microprocessor input. Normally a high level, IRQ goes low when an interrupt occurs.

DB0 - DB7 (Data Bus)

The DB0-DB7 pins are the eight data lines used for transfer of data between the processor and the SY6551. These lines are bi-directional and are normally high-impedance except during Read cycles when selected.

CS0, CS1 (Chip Selects)

The two chip select inputs are normally connected to the processor address lines either directly or through decoders. The SY6551 is selected when CS0 is high and CS1 is low.

RS0, RS1 (Register Selects)

The two register select lines are normally connected to the processor address lines to allow the processor to select the various SY6551 internal registers. The following table indicates the internal register select coding:

MICRO-PROCESSORS

RS ₁	RS ₀	Write	Read
0	0	Transmit Data Register	Receiver Data Register
0	1	Programmed Reset (Data is "Don't Care")	Status Register
1	0	Command Register	
1	1	Control Register	

The table shows that only the Command and Control registers are read/write. The Programmed Reset operation does not cause any data transfer, but is used to clear the SY6551 registers. The Programmed Reset is slightly different from the Hardware Reset (\overline{RES}) and these differences are described in the individual register definitions.

ACIA/Modem Interface Signal Description

XTAL1, XTAL2 (Crystal Pins)

These pins are normally directly connected to the external crystal (1.8432-MHz) used to derive the various baud rates. Alternatively, an externally generated clock may be used to drive the XTAL1 pin, in which case the XTAL2 pin must float.

TxD (Transmit Data)

The TxD output line is used to transfer serial NRZ (non-return-to-zero) data to the modem. The LSB (least significant bit) of the Transmit Data Register is the first data bit transmitted and the rate of data transmission is determined by the baud rate selected.

RxD (Receive Data)

The RxD input line is used to transfer serial NRZ data into the ACIA from the modem, LSB first. The receiver data rate is either the programmed baud rate or the rate of an externally generated receiver clock. This selection is made by programming the Control Register.

RxC (Receive Clock)

The RxC is a bi-directional pin which serves as either the receiver 16x clock input or the receiver 16x clock output. The latter mode results if the internal baud rate generator is selected for receiver data clocking.

RTS (Request to Send)

The RTS output pin is used to control the modem from the processor. The state of the RTS pin is determined by the contents of the Command Register.

CTS (Clear to Send)

The CTS input pin is used to control the transmitter operation. The enable state is with \overline{CTS} low. The transmitter is automatically disabled if \overline{CTS} is high.

\overline{DTR} (Data Terminal Ready)

This output pin is used to indicate the status of the SY6551 to the modem. A low on \overline{DTR} indicates the SY6551 is enabled and a high indicates it is disabled. The processor controls this pin via bit 0 of the Command Register.

\overline{DSR} (Data Set Ready)

The \overline{DSR} input pin is used to indicate to the SY6551 the status of the modem. A low indicates the "ready" state and a high, "not-ready." \overline{DSR} is a high-impedance input and must not be a no-connect. If unused, it should be driven high or low, but not switched.

Note: If Command Register Bit 0 = 1 and a change of state on \overline{DSR} occurs, \overline{IRQ} will be set, and Status Register Bit 6 will reflect the new level. The state of \overline{DSR} does not affect either Transmitter or Receiver operation.

\overline{DCD} (Data Carrier Detect)

The \overline{DCD} input pin is used to indicate to the SY6551 the status of the carrier-detect output of the modem. A low indicates that the modem carrier signal is present and a high, that it is not. \overline{DCD} , like \overline{DSR} , is a high-impedance input and must not be a no-connect.

Note: If Command Register Bit 0 = 1 and a change of state on \overline{DCD} occurs, \overline{IRQ} will be set, and Status Register Bit 5 will reflect the new level. The state of \overline{DCD} does not affect Transmitter operation, but must be low for the Receiver to operate.

Internal Organization

The Transmitter/Receiver sections of the SY6551 are depicted by the block diagram in Figure 5.

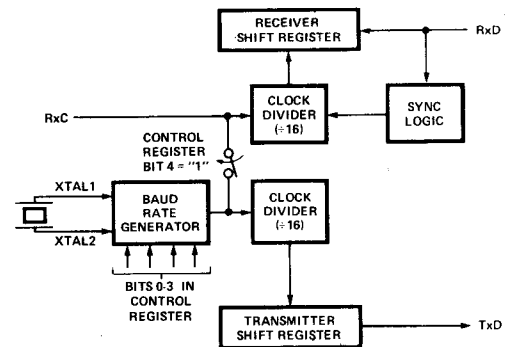

Figure 5. Transmitter/Receiver Clock Circuits

Bits 0-3 of the Control Register select the divisor used to generate the baud rate for the Transmitter. If the Receiver clock is to use the same baud rate as the Transmitter, then RxC becomes an output pin and can be used to slave other circuits to the SY6551.

Control Register

The Control Register is used to select the desired mode for the SY6551. The word length, number of stop bits, and clock controls are all determined by the Control Register, which is depicted in Figure 6.

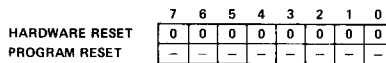
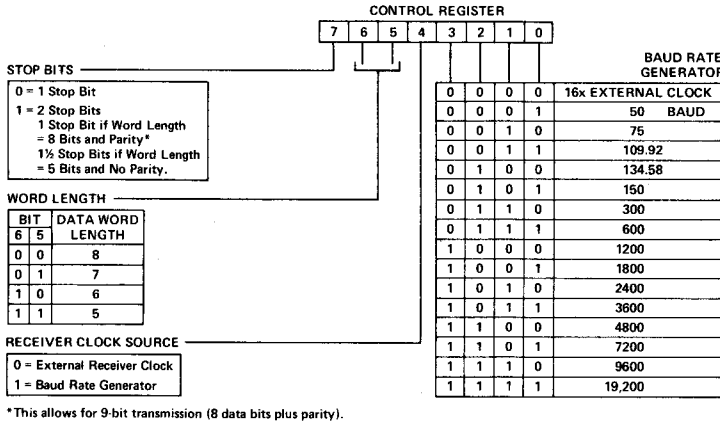

Figure 6. Control Register Format

Command Register

The Command Register is used to control Specific Transmit/Receive functions and is shown in Figure 7.

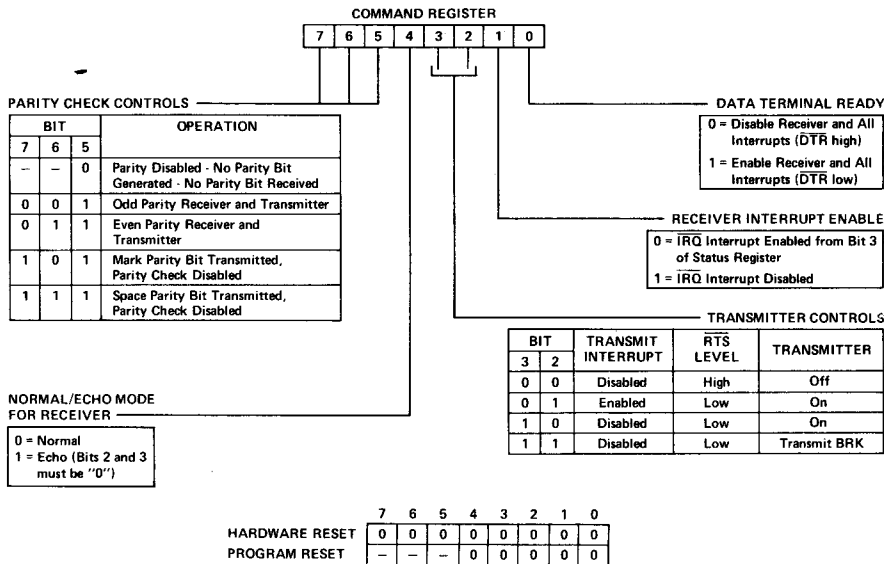
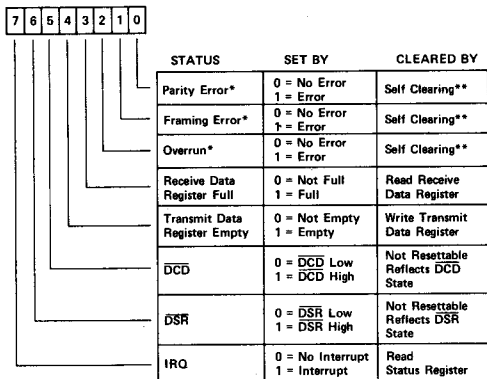

Figure 7. Command Register Format

MICRO-PROCESSORS

Status Register

The Status Register is used to indicate to the processor the status of various SY6551 functions and is outlined in Figure 8.



*NO INTERRUPT GENERATED FOR THESE CONDITIONS.
 **CLEARED AUTOMATICALLY AFTER A READ OF RDR AND THE NEXT ERROR FREE RECEIPT OF DATA.

	7	6	5	4	3	2	1	0
HARDWARE RESET	0	-	-	1	0	0	0	0
PROGRAM RESET	-	-	-	-	-	0	-	-

Figure 8. Status Register Format

Transmit and Receive Data Registers

These registers are used as temporary data storage for the 6551 Transmit and Receive circuits. The Transmit Data Register is characterized as follows:

- Bit 0 is the leading bit to be transmitted.
- Unused data bits are the high-order bits and are "don't care" for transmission.

The Receive Data Register is characterized in a similar fashion:

- Bit 0 is the leading bit received.
- Unused data bits are the high-order bits and are "0" for the receiver.
- Parity bits are not contained in the Receive Data Register, but are stripped-off after being used for external parity checking. Parity and all unused high-order bits are "0".

Figure 9 illustrates a single transmitted or received data word, for the example of 8 data bits, parity, and 1 stop bit.

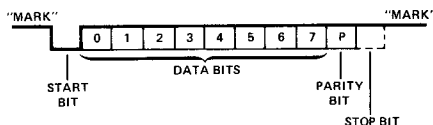

Figure 9. Serial Data Stream Example

Package Availability 28 Pin Ceramic
 28 Pin Cerdip
 28 Pin Plastic

Ordering Information

Part No.	Package	Clock Rate
SYC6551	Ceramic	1 MHz
SYD6551	Cerdip	1 MHz
SYP6551	Plastic	1 MHz
SYC6551A	Ceramic	2 MHz
SYD6551A	Ceramic	2 MHz
SYP6551A	Plastic	2 MHz