

TRS-80 Acoustic Coupler for use with the Model 100

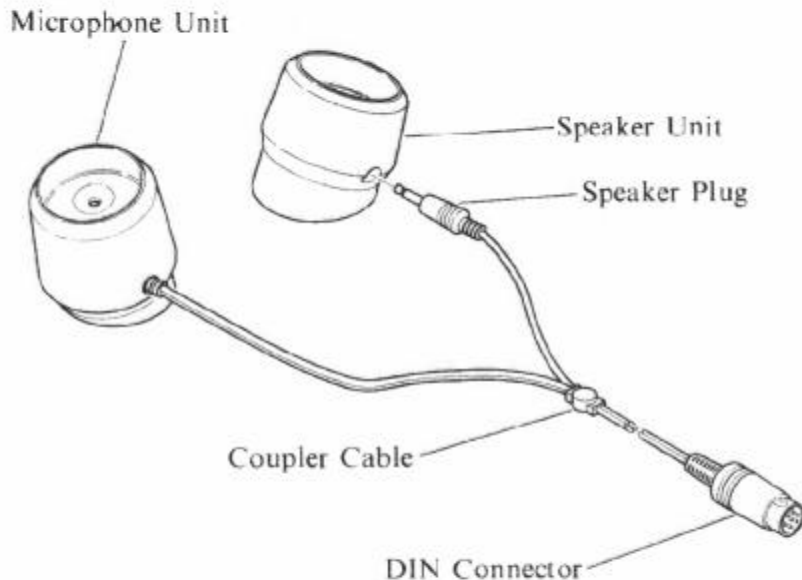

26-3805A



The Model 100 Acoustic Coupler enables your Model 100 to be connected to a telephone that does not allow direct connect (such as a phone in a telephone booth).

When using or handling the Acoustic Coupler, keep the following points in mind:

- Avoid excessive strain on the coupler cable. Place the coupler units as close to the telephone as possible. Do not tug on the cable.
- Before you plug the DIN connector into the Model 100, make sure the Acoustic Cups are attached to the coupler cable first. If you're not using the acoustic modem, make sure the DIN connector is disconnected from the Model 100.
- Do not use the Acoustic Coupler with any telephones, other than rotary-dial or pushbutton types with standard handsets.
- While data is being received or transmitted through the coupler units, do not touch the coupler units or subject the cups to significant vibration and noise. This helps prevent data errors. The same precautions should be observed with the desk upon which the coupler units are placed.
- The condition of the telephone line might sometimes disturb the transmission through the Acoustic Coupler. If the line fails, call again.

Connecting the Acoustic Coupler to the Model 100

1. Connect the speaker plug, located at one end of the coupler cable set, to the speaker unit. (Refer to the illustration on page 1.)
2. Connect the DIN connector to the **PHONE** connector on the rear side of your Model 100.
3. Place the microphone unit securely over the earpiece of a standard telephone handset; then place the speaker unit over the mouthpiece of the handset.

Note: Be sure that the units are firmly linked with the handset, or poor acoustic characteristics will result.

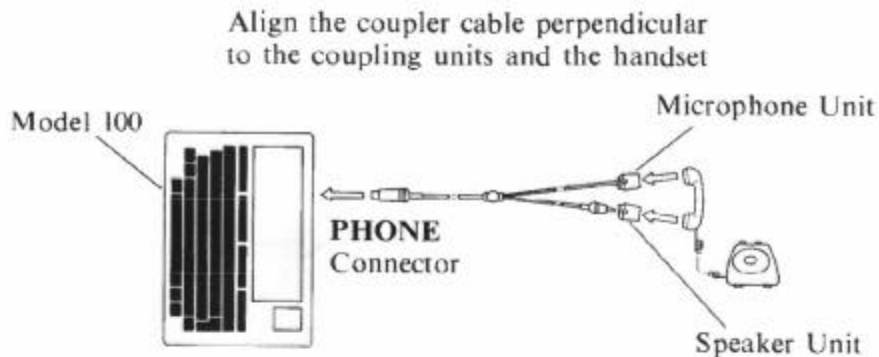

Figure 1

4. When the microphone and speaker units are coupled to the handset, place them on a flat surface, shown in Figure 2.

Note: Avoid laying the handset on its side on any hard surface, such as a desk, since this will allow exterior vibrations to be picked up; thus, data errors could result. When possible, it is highly recommended that the Acoustic Coupler units be placed on a one-inch thick piece of low-density foam.

Correct positioning of the handset with the Acoustic Coupler units in place.



Figure 2

Incorrect positioning allows exterior vibrations to enter the handset; this could cause data errors.



Figure 3

5. Set the **DIR/ACP** switch on your Model 100 to **ACP**. Connection is now complete and the Model 100 is ready for use.

Note: See the owner's manual of your Model 100 for specific instructions regarding the Acoustic Coupler.

Specifications

Applicable Telephone Type	Type 500 (Rotary Dial)/ Type 2500 (Pushbutton) with standard handset
Communication Mode	Full/Half duplex
Modulation Type	F.S.K.
Data Rate	300 baud
Operation Mode	Originate/Answer
Transmitting Frequency Originate:	1070 to 1270 Hz
Answer:	2025 to 2225 Hz
Receiving Frequency Originate:	2025 to 2225 Hz
Answer:	1070 to 1270 Hz
Transmitting Sound Pressure Level	Less than 1 N/m ² (0.3 to 3.4 kHz)
Carrier Detection Level Half Duplex:	-40 dBm
Full Duplex:	-30 dBm
Environmental Noise Allowance	Operative stably with less than 85 phons
Operating Voltage	+5 V
Power Consumption	Less than 30mW
Operating Temperature range	41°F to 104°F or 5°C to 40°C
Operating Humidity Range	20% to 80% RH (non-condensation)
Dimensions	φ76 mm (diameter) × 76 mm (height) 3" (diameter) × 3" (height)
Weight	330g (11.6 oz) Including cableset

To avoid data errors and obtain the longest service life, do not use the Acoustic Coupler where it will be:

- Subjected to extremely high or low temperatures or high humidity.
- Exposed to excessive vibration.
- Surrounded by excessive exterior noises.
- Close to very high voltage or appliances using a high voltage.

LIMITED WARRANTY

I. CUSTOMER OBLIGATIONS

- A. CUSTOMER assumes full responsibility that this Radio Shack computer hardware purchased (the "Equipment"), and any copies of Radio Shack software included with the Equipment or licensed separately (the "Software") meets the specifications, capacity, capabilities, versatility, and other requirements of CUSTOMER.
- B. CUSTOMER assumes full responsibility for the condition and effectiveness of the operating environment in which the Equipment and Software are to function, and for its installation.

II. RADIO SHACK LIMITED WARRANTIES AND CONDITIONS OF SALE

- A. For a period of ninety (90) calendar days from the date of the Radio Shack sales document received upon purchase of the Equipment, RADIO SHACK warrants to the original CUSTOMER that the Equipment and the medium upon which the Software is stored is free from manufacturing defects. THIS WARRANTY IS ONLY APPLICABLE TO PURCHASES OF RADIO SHACK EQUIPMENT BY THE ORIGINAL CUSTOMER FROM RADIO SHACK COMPANY-OWNED COMPUTER CENTERS, RETAIL STORES AND FROM RADIO SHACK FRANCHISEES AND DEALERS AT ITS AUTHORIZED LOCATION. The warranty is void if the Equipment's case or cabinet has been opened, or if the Equipment or Software has been subjected to improper or abnormal use. If a manufacturing defect is discovered during the stated warranty period, the defective Equipment must be returned to a Radio Shack Computer Center, a Radio Shack retail store, participating Radio Shack franchisee or Radio Shack dealer for repair, along with a copy of the sales document or lease agreement. The original CUSTOMER'S sole and exclusive remedy in the event of a defect is limited to the correction of the defect by repair, replacement, or refund of the purchase price, at RADIO SHACK'S election and sole expense. RADIO SHACK has no obligation to replace or repair expendable items.
- B. RADIO SHACK makes no warranty as to the design, capability, capacity, or suitability for use of the Software, except as provided in this paragraph. Software is licensed on an "AS IS" basis, without warranty. The original CUSTOMER'S exclusive remedy, in the event of a Software manufacturing defect, is its repair or replacement within thirty (30) calendar days of the date of the Radio Shack sales document received upon license of the Software. The defective Software shall be returned to a Radio Shack Computer Center, a Radio Shack retail store, participating Radio Shack franchisee or Radio Shack dealer along with the sales document.
- C. Except as provided herein no employee, agent, franchisee, dealer or other person is authorized to give any warranties of any nature on behalf of RADIO SHACK.
- D. Except as provided herein, RADIO SHACK MAKES NO WARRANTIES, INCLUDING WARRANTIES OF MERCHANTABILITY OR FITNESS FOR A PARTICULAR PURPOSE.
- E. Some states do not allow limitations on how long an implied warranty lasts, so the above limitation(s) may not apply to CUSTOMER.

III. LIMITATION OF LIABILITY

- A. EXCEPT AS PROVIDED HEREIN, RADIO SHACK SHALL HAVE NO LIABILITY OR RESPONSIBILITY TO CUSTOMER OR ANY OTHER PERSON OR ENTITY WITH RESPECT TO ANY LIABILITY, LOSS OR DAMAGE CAUSED OR ALLEGED TO BE CAUSED DIRECTLY OR INDIRECTLY BY "EQUIPMENT" OR "SOFTWARE" SOLD, LEASED, LICENSED OR FURNISHED BY RADIO SHACK, INCLUDING, BUT NOT LIMITED TO, ANY INTERRUPTION OF SERVICE, LOSS OF BUSINESS OR ANTICIPATORY PROFITS, OR CONSEQUENTIAL DAMAGES RESULTING FROM THE USE OR OPERATION OF THE "EQUIPMENT" OR "SOFTWARE". IN NO EVENT SHALL RADIO SHACK BE LIABLE FOR LOSS OF PROFITS, OR ANY INDIRECT, SPECIAL, OR CONSEQUENTIAL DAMAGES ARISING OUT OF ANY BREACH OF THIS WARRANTY OR IN ANY MANNER ARISING OUT OF OR CONNECTED WITH THE SALE, LEASE, LICENSE, USE OR ANTICIPATED USE OF THE "EQUIPMENT" OR "SOFTWARE".

NOTWITHSTANDING THE ABOVE LIMITATIONS AND WARRANTIES, RADIO SHACK'S LIABILITY HEREUNDER FOR DAMAGES INCURRED BY CUSTOMER OR OTHERS SHALL NOT EXCEED THE AMOUNT PAID BY CUSTOMER FOR THE PARTICULAR "EQUIPMENT" OR "SOFTWARE" INVOLVED.

- B. RADIO SHACK shall not be liable for any damages caused by delay in delivering or furnishing Equipment and/or Software.
- C. No action arising out of any claimed breach of this Warranty or transactions under this Warranty may be brought more than two (2) years after the cause of action has accrued or more than four (4) years after the date of the Radio Shack sales document for the Equipment or Software, whichever first occurs.
- D. Some states do not allow the limitation or exclusion of incidental or consequential damages, so the above limitation(s) or exclusion(s) may not apply to CUSTOMER.

IV. RADIO SHACK SOFTWARE LICENSE

RADIO SHACK grants to CUSTOMER a non-exclusive, paid-up license to use the RADIO SHACK Software on one computer, subject to the following provisions:

- A. Except as otherwise provided in this Software License, applicable copyright laws shall apply to the Software.
- B. Title to the medium on which the Software is recorded (cassette and/or diskette) or stored (ROM) is transferred to CUSTOMER, but not title to the Software.
- C. CUSTOMER may use Software on one host computer and access that Software through one or more terminals if the Software permits this function.
- D. CUSTOMER shall not use, make, manufacture, or reproduce copies of Software except for use on one computer and as is specifically provided in this Software License. Customer is expressly prohibited from disassembling the Software.
- E. CUSTOMER is permitted to make additional copies of the Software only for backup or archival purposes or if additional copies are required in the operation of one computer with the Software, but only to the extent the Software allows a backup copy to be made. However, for TRSDOS Software, CUSTOMER is permitted to make a limited number of additional copies for CUSTOMER'S own use.
- F. CUSTOMER may resell or distribute unmodified copies of the Software provided CUSTOMER has purchased one copy of the Software for each one sold or distributed. The provisions of this Software License shall also be applicable to third parties receiving copies of the Software from CUSTOMER.
- G. All copyright notices shall be retained on all copies of the Software.

V. APPLICABILITY OF WARRANTY

- A. The terms and conditions of this Warranty are applicable as between RADIO SHACK and CUSTOMER to either a sale of the Equipment and/or Software License to CUSTOMER or to a transaction whereby RADIO SHACK sells or conveys such Equipment to a third party for lease to CUSTOMER.
- B. The limitations of liability and Warranty provisions herein shall inure to the benefit of RADIO SHACK, the author, owner and/or licensor of the Software and any manufacturer of the Equipment sold by RADIO SHACK.

VI. STATE LAW RIGHTS

The warranties granted herein give the original CUSTOMER specific legal rights, and the original CUSTOMER may have other rights which vary from state to state.

SERVICE POLICY

Radio Shack's nationwide network of service facilities provides quick, convenient, and reliable repair services for all of its computer products, in most instances. Warranty service will be performed in accordance with Radio Shack's Limited Warranty. Non-warranty service will be provided at reasonable parts and labor costs.

Because of the sensitivity of computer equipment, and the problems which can result from improper servicing, the following limitations also apply to the services offered by Radio Shack:

1. If any of the warranty seals on any Radio Shack computer products are broken, Radio Shack reserves the right to refuse to service the equipment or to void any remaining warranty on the equipment.

2. If any Radio Shack computer equipment has been modified so that it is not within manufacturer's specifications, including, but not limited to, the installation of any non-Radio Shack parts, components, or replacement boards, then Radio Shack reserves the right to refuse to service the equipment, void any remaining warranty, remove and replace any non-Radio Shack part found in the equipment, and perform whatever modifications are necessary to return the equipment to original factory manufacturer's specifications.

3. The cost for the labor and parts required to return the Radio Shack computer equipment to original manufacturer's specifications will be charged to the customer in addition to the normal repair charge.

RADIO SHACK, A DIVISION OF TANDY CORPORATION

U.S.A.: FORT WORTH, TEXAS 76102
CANADA: BARRIE, ONTARIO L4M 4W5

TANDY CORPORATION

AUSTRALIA	BELGIUM	U. K.
91 KURRAJONG ROAD MOUNT DRUITT, N.S.W. 2770	PARC INDUSTRIEL DE NANINNE 5140 NANINNE	BILSTON ROAD WEDNESBURY WEST MIDLANDS WS10 7JN